

Si-82 PACK 1

CENTRIFUGAL PUMP



Durable pump

The Si-82 pump is designed to be easily installed whatever the layout of the premises. Capable of evacuating up to 500 l/h, the Si-82 pump is suitable for air conditioning units and industrial refrigeration displays. Strong, the Si-82 tolerates charged, high temperature and acidic condensates (pH>2.5) produced by gas condensing boilers.

BENEFITS

● High performance

- Can discharge condensates **up to 5 m**
- **Up to 500 l/h**, for shorter running time
- **Low sound level** – quiet operation

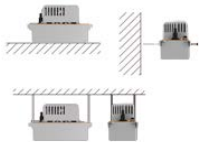

● Installation in any place

Pump can be floor mounted, attached on a wall or hanging from a ceiling.

● Versatile

Easily removable tank and reversible pump, to allow mounting rather on the left or on the right of the application and choosing the side of the water exit.



● Easy electrical connection

Plug-in power cord to facilitate installation and maintenance.



● Easy hydraulic connection

- Quarter turn easily removable check valve, designed to facilitate \varnothing int. 10 mm (3/8") hose plug in.
- 4 inlet holes \varnothing 30 mm (1" ³/₁₆)



● High resistance

- **Oil and acid resistant** float
- Mechanical structure **resistant to shocks**

KIT CONTENTS



- One-piece centrifugal pump with tank (2L)
- Integrated barb end check valve \varnothing ext. 10 mm (3/8")
- Plug-in power (2m, **European plug**) & safety switch cord (1.5m, bare ends)
- Straight connector \varnothing ext. 10 mm (3/8") – \varnothing ext. 6 mm (1/4")
- 2 screws + 2 plugs

APPLICATIONS

- Column air conditioning units • Multi cassettes • Ducted units
- Gas condensing boilers • High efficiency gas furnace
- Refrigerating display cabinets • Evaporators

TECHNICAL SPECIFICATION

Max. flow rate	500 l/h
Max. discharge head	5 m
Max pressure	5.4 m (flowrate =0)
Sound level in application at 1m(3.3ft): ≤ 45 dBA (Measured in Sauer mann acoustic lab, pump operating with water)	
Mains supply	230V~ 50Hz - 70 W – 0.75A
Detection levels	On : 53mm, Off : 42mm, Safety : 64mm
Safety switch	NC 4 A resistive – 250V
Max. condensate temperature	65°C, 80°C in short peak
Max. condensate acidity	pH > 2.5 (Gas condensing boilers)
Thermal protection (overheating)	105°C (auto-reset)
Operating conditions	30%: 3s ON – 7s OFF
Protection	IP20
Safety standards	CE and EAC
RoHS directive	Compliant
WEEE directive	Compliant
Weight (including box)	2.5 kg
Packaging	4 pcs: L400xW300xH200 mm
Pallet quantity	64 pieces

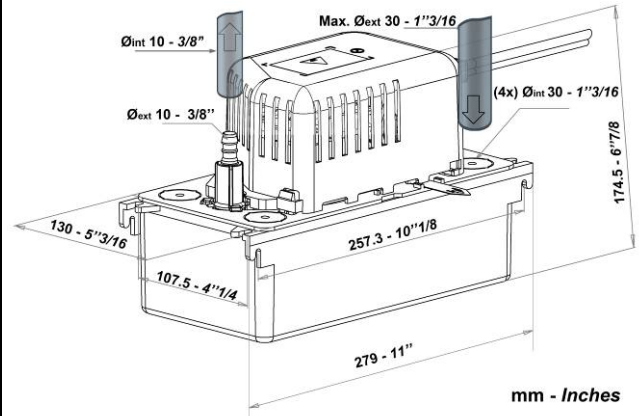

ACTUAL FLOW RATES (l/h)

Vertical Discharge head	Total tube length (Ø int. 10 mm, 3/8")			
	5 m	10 m	20 m	30 m
1 m	380	300	240	190
2 m	310	260	200	150
3 m	240	200	145	110
4 m	150	130	80	60
5 m	30	20	0	0

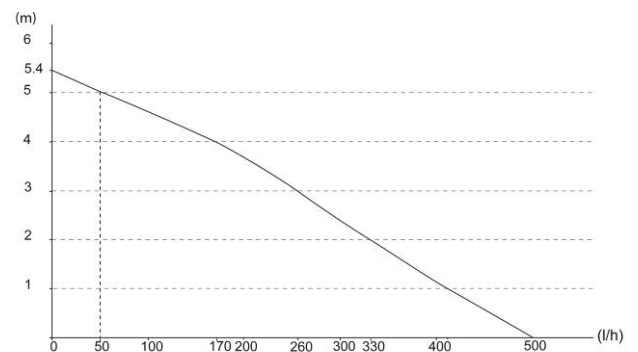

RECOMMENDED ACCESSORIES



Hose Ø int. 10mm (3/8")
 ACC00911: 25 m
 ACC00915: Braided, 25 m



Check valve
 For replacement
 Ø ext 10 mm (3/8")
 ACC00925



Inlet rubber adapter
 Ø int. 15-20-24-32-40 mm
 (Ø int. 5/8"-3/4"-1"- 1 1/4"-1 1/2")
 ACC00939

Non-contractual document. We reserve the right to modify the characteristics on our products without prior notice.